

4500-MTS

- 4 to 36 source-measure channels
- Programmable DC sources, up to 10V @ 10mA or 1A @ 6V
- Supports parallel testing with up to 8 autonomous groups of channels
- Real-time parallel source and measurement sequences
- Fast measurement integration rates as short as 0.002 NPLC
- Easy to program parallel I-V sweeps and step-and-sweep sequences
- Open PC/PCI architecture allows easy integration of software and hardware
- Software drivers optimized for popular test development environments
- Ethernet and Windows 2000 support popular network interfaces that connect to corporate networks and the Internet
- Test applications can be developed and executed on a remote PC or on the Model 4500-MTS

Multi-Channel I-V Test System



The Model 4500-MTS Multi-Channel I-V Test System is a DC source-measure test system that is optimized for high speed parallel testing. This multi-channel system supports up to 36 source-measure channels while automatically managing complex channel coordination tasks such as inter channel triggering and communications. In addition, the Model 4500-MTS reduces system complexity by eliminating the need for external trigger control and instrument communications buses.

Unmatched Channel Density

The Model 4510-QIVC and 4511-QIVC plug-in cards offer powerful and precise source-measure capability. Each card provides four channels, and each channel includes a current source subchannel and a voltage source subchannel as shown in Figure 1. Each channel includes an instrument grade A/D converter for the highest possible throughput without compromising precision. With nine available slots, the Model 4500-MTS can be configured for a wide range of applications requiring as few as 4 channels to as many as 72 subchannels.

A current source subchannel consists of a programmable current source with current readback, four-wire voltage measurement, and a programmable voltage clamp. Each QIVC model has three current source ranges:

QIVC Model	Current Source Ranges
4510	30 mA, 100 mA, 500 mA
4511	100 mA, 300 mA, 1 A

A voltage source subchannel consists of a programmable voltage source of up to 10V with voltage readback and current measurement with three ranges: 10 μ A, 500 μ A, and 10mA.

Each subchannel has independently controllable output modes that include high impedance and short circuit modes. The high impedance output mode allows both the current and the voltage source subchannels to source the same DUT (device under test) simultaneously, while each of the subchannels is supporting a different test function. The short circuit mode provides for improved ESD DUT protection when the output is off.

APPLICATIONS

Multi site parallel testing, including:

- Wafer level HiB LED
- Photonic integrated circuit
- MEMS/MOEMS life test
- Used in RFIC test as intelligent power supply subsystem
- Wafer and package level VCSEL test
- Laser diode characterization
- Multi section tunable laser diode test

Multi-channel I-V test

SOURCE AND MEASURE

1.888.KEITHLEY (U.S. only)

www.keithley.com

KEITHLEY

A GREATER MEASURE OF CONFIDENCE

4500-MTS

Ordering Information

4500-MTS/F
MTS Chassis with Flat Panel Option

4500-MTS/C
MTS Chassis without Flat Panel Option

Note: 4500-MTS must be purchased with one or more QIVC cards:

4510-QIVC
Low Power Quad I/V Card

4511-QIVC
High Power Quad I/V Card

ACCESSORIES SUPPLIED w/4500-MTS

4500 User's Manual
4510/11-QIVC Drivers (Installed)

ACCESSORIES SUPPLIED w/451x-QIVC

4510-QIVC and 4511-QIVC Quad I-V Cards User's Manual
OPTO-950-01D CD Manual
4500-CQIV-* QIVC Cable (*= 0.5, 1, 2, or 3m)
4500-CILK-* QIVC Interlock Cable (*= 0.5, 1, 2, or 3m)
4500-CIV-KIT-1_A 15-pin female D-sub, solder cup, mates with 4500-CQIV.* (4)
4500-QIVC-TLS QIVC Test lead set, 15-pin D-sub to 8 alligator clips
4500-QILK-PLUG QIVC Interlock override plug, mates to 4500-CILK.*

ACCESSORIES AVAILABLE

4510-QIVC Low Power Quad I-V Card
4511-QIVC High Power Quad I-V Card
4500-CQIV-* QIVC Cable (*= 0.5, 1, 2, 3m)
4500-CILK-* QIVC Interlock Cable (*= 0.5, 1, 2, 3m)
4500-CIV-KIT-1_A 15-pin female D-sub, solder cup, mates with 4500-CQIV.*
4500-ILK-KIT-1_A 14-pin MDR connector and shell for 451x-QIVC
4500-QIVC-TLS QIVC Test lead set, 15-pin D-sub to 8 alligator clips
4500-QILK-PLUG QIVC Interlock override plug, mates to 4500-CILK.*

Multi-Channel I-V Test System

Deterministic Performance

Complex tests, such as nested sweeps, can easily be performed with deterministic timing, unaffected by latencies normally associated with multi-channel systems. This is due to the real-time controller (RTC) embedded in each Series 4500 card. These RTCs manage test execution independently from the PC in the chassis. The RTCs, in conjunction with the trigger bus, allow groups of channels spanning one or more cards to act synchronously, yet independently of other groups of channels. The RTCs also record sweep measurement results during a test sequence for transfer via the PCI bus once the test is complete. Additionally, an RTC is able to execute preprogrammed sequences such as linear sweeps and list sweeps.

Parallel Testing Maximizes Throughput

Parallel test is used when throughput is a high priority and the test execution time is significant compared to component handling times. Figure 2 shows how throughput improves when the number of channels dedicated to a synchronous parallel test system is increased. In this case, the test time per channel actually decreases with the addition of channels. This is because channel configuration and test happen in parallel, while only test results are downloaded sequentially. Figure 3 shows a concurrent test environment where groups of channels execute asynchronously. In this case, the RTCs in the Model 4500 cards execute completely independently of other groups and independently of the embedded PC. This allows the PC embedded in the Model 4500-MTS to manage coordination between the channel groups and the component handling system.

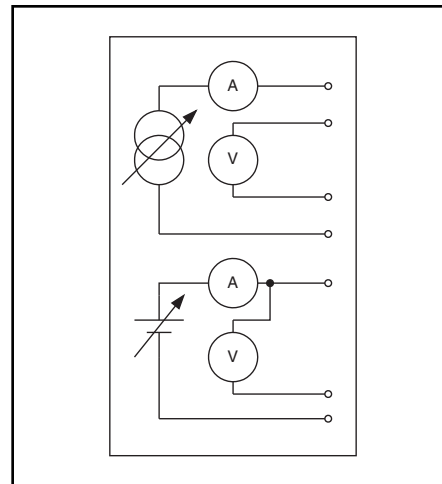
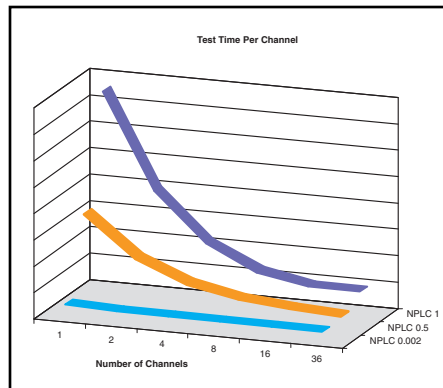

Figure 1. Basic block diagram of the source and measurement components in one channel of a Model 4500-QIVC.

Figure 2. When test configuration and test execution happen in parallel, the addition of more channels does not increase the test time—it only increases the download time of the test results. Here the download time of the test results is a fraction of the configuration and test time. As a result, the average speed per channel is increased with the addition of more channels.

1.888.KEITHLEY (U.S. only)

www.keithley.com

KEITHLEY

A GREATER MEASURE OF CONFIDENCE

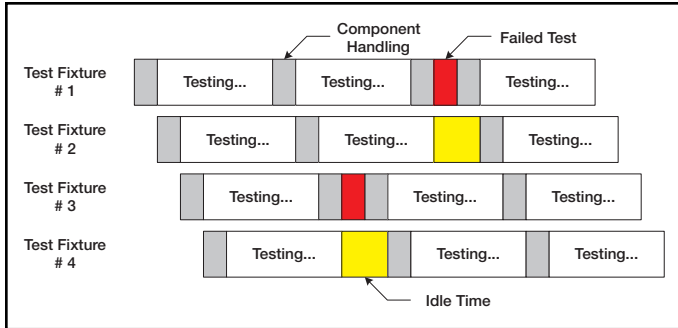

Figure 3. The architecture of the Model 4500-MTS allows channel groups to execute autonomously. Here, four DUTs are shown being tested concurrently. Each DUT is tested by a different group of channels working independently. Each channel group's test sequencing is offloaded to the Model 4500 cards' RTCs.

Simplified Programming

The Model 4500-MTS software architecture allows the unit to be used either as an instrument, being controlled by a remote PC, or as a self contained system. The architecture allows the same application code to be executed either on a remote PC or on the Model 4500-MTS without any changes. Figure 4 shows the communications flow between the software and hardware components of the system.

The Series 4500 card drivers communicate with the 4500 Real-Time Manager via TCP/IP. This communication layer allows the application code to communicate with the 4500 Real-Time Manager locally or over the Ethernet. In addition to allowing remote control, the 4500 Real-Time Manager also:

- Manages groups of channels – Coordinates groups of channels that execute tests as an organized group. It supports up to eight channel groups. Each channel group executes independently of all other channel groups.
- Channel configuration – Configures each channel based on input from the Series 4500 card driver. The 4500 Real-Time Manager greatly reduces the programming complexity by configuring the inter- and intra-card sequencing. It also eliminates complex trigger model programming.
- Manages multiple users – Allows multiple users to connect to the Model 4500-MTS through the Ethernet connection. The 4500 Real-Time Manager ensures that each user has access to unused hardware resources and does not interfere with other users. It also ensures that the resultant test data from a channel group is sent to the channel group's owner.

Open System Architecture

The Model 4500-MTS's architecture is based on standard PC technology including Windows 2000, the PCI bus, and the ISA bus. While the Model 4500-MTS can be used as a remotely controlled instrument, it can also be used as a self-contained system.

Application development environments such as Microsoft Visual Basic or LabVIEW can be loaded directly onto the Model 4500-MTS and used to build applications for controlling the Model 4500-MTS and other instruments. Third party PCI cards can be installed in the system to provide a broad range of capabilities, including: a GPIB interface for controlling external instruments, digital I/O to interface with component handlers and robots, etc.

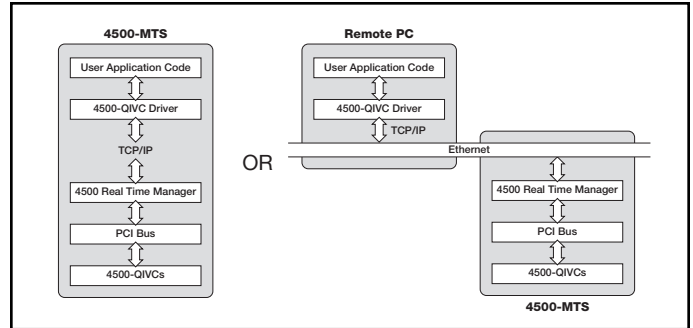

Figure 4. The architecture is designed to allow programs to execute locally or remotely without modifying application code.

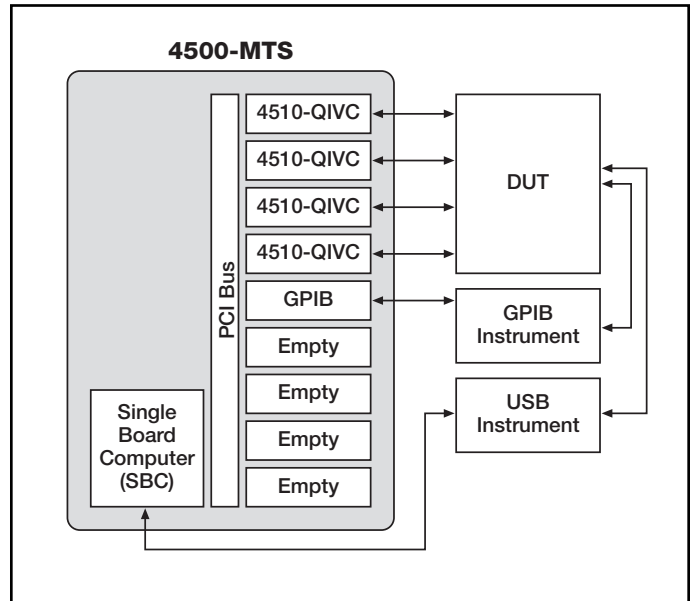

Figure 5. The open system architecture of the Model 4500-MTS allows it to operate as the test system controller.

Series 451x-QIVC Specifications

The 451x-QIVC cards incorporate four independent, isolated measurement channels on a single card. Each channel consists of a:

- Programmable multi-range current source with programmable voltage clamp, source read-back, and precision voltage measurement.
- Programmable voltage source with source read-back and precision multi-range current measurement.

The 451x-QIVC cards are recommended for use only with the 4500-MTS Product.

CURRENT SOURCE

RANGE	MODEL	PROGRAMMING RESOLUTION	PROGRAMMING ACCURACY (1 Year) (23°C ±5°C)			PROGRAMMING ACCURACY (24 Hr.) ¹ (23°C ±1°C)			NOISE TYPICAL ² (peak to peak) 0.1Hz-150kHz
			±(%rdg. + amps + amps * (V _O /V _{IS}) - I _O /I _{IS}) ⁵			±(%rdg. + amps + amps * (V _O /V _{IS}) - I _O /I _{IS}) ⁵			
±30.0000 mA	4510	2 μA	0.08%	7.4 μA	4.3 μA	0.065%	3.5 μA	4.3 μA	100 μA
±100.000 mA	4510/4511	5 μA	0.08%	25 μA	14.3 μA	0.065%	13 μA	14.3 μA	100 μA
±300.000 mA	4511	15 μA	0.08%	75 μA	43 μA	0.065%	40 μA	43 μA	200 μA
±500.000 mA	4510	25 μA	0.08%	122 μA	72 μA	0.065%	42 μA	72 μA	250 μA
±1.000 A	4511	50 μA	0.08%	250 μA	144 μA	0.065%	84 μA	144 μA	500 μA

RANGE	MODEL	DEFAULT MEASUREMENT RESOLUTION	MEASUREMENT ACCURACY (1 Year) (23°C ±5°C)			MEASUREMENT ACCURACY (24 Hr.) ¹ (23°C ±1°C)			TYPICAL ^{2,7} OUTPUT SLEW RATE mA/μs
			±(%rdg. + amps + amps * (V _O /V _{IS}) - I _O /I _{IS}) ⁵			±(%rdg. + amps + amps * (V _O /V _{IS}) - I _O /I _{IS}) ⁵			
±30.0000 mA	4510	0.1 μA	0.065%	2.5 μA	4.3 μA	0.065%	1.5 μA	4.3 μA	0.3
±100.000 mA	4510/4511	1 μA	0.065%	8 μA	14.3 μA	0.065%	4 μA	14.3 μA	1
±300.000 mA	4511	3 μA	0.065%	12 μA	43 μA	0.065%	9 μA	43 μA	3
±500.000 mA	4510	5 μA	0.065%	20 μA	72 μA	0.065%	10 μA	72 μA	5
±1.000 A	4511	10 μA	0.065%	40 μA	143 μA	0.065%	20 μA	143 μA	10

CURRENT OUTPUT SETTling TIME: 150ms to 0.1% of final value typical, resistive load after command is processed³.

CURRENT SOURCE SHORTING RELAY: Shorts load when output is turned off or when interlock condition exists.

CURRENT SOURCE OVERSHOOT: < 0.1%, full-scale step, resistive load.

CURRENT SOURCE LONG TERM STABILITY: ±20ppm/hour typical, ±1°C ambient, 30 minute warm-up required.

OVER TEMPERATURE PROTECTION: Internally sensed temperature overload puts unit in standby mode.

LOAD INDUCTANCE: 200μH maximum⁴.

CURRENT SOURCE LOAD VOLTAGE MEASUREMENT

RANGE	MEASUREMENT ACCURACY (1 Year) (23°C ±5°C)	MEASUREMENT ACCURACY (24 Hr.) ¹ (23°C ±1°C)	DEFAULT MEASUREMENT RESOLUTION
	±(%rdg. + volts)	±(%rdg. + volts)	
±6.0000 V	0.06% + 2 mV	0.025% + 250 μV	10 μV

REMOTE/LOCAL SENSE: Automatic; remote sense and proper zero are required to meet rated accuracy.
REMOTE SENSE: Up to 0.5V drop from card bracket to DUT.

CURRENT SOURCE VOLTAGE COMPLIANCE:

RANGE	PROGRAMMING RESOLUTION	PROGRAMMING ACCURACY (1 Year) (23°C ±5°C)	PROGRAMMING ACCURACY (24 Hr.) ¹ (23°C ±1°C)
		±(%rdg. + volts)	±(%rdg. + volts)
±6.000 V	200 μV	0.1% + 4.7 mV	0.07% + 3.7 mV

MINIMUM COMPLIANCE VOLTAGE: 100mV

VOLTAGE SOURCE

FULL SCALE	PROGRAMMING RESOLUTION	PROGRAMMING ⁶ ACCURACY (1 Year) (23°C ±5°C)	PROGRAMMING ACCURACY (24 Hour) ¹ (23°C ±1°C)	DEFAULT MEASUREMENT RESOLUTION	MEASUREMENT ACCURACY (1 Year) (23°C ±5°C)	MEASUREMENT ACCURACY (24 Hour) ¹ (23°C ±1°C)
		±(%rdg. + volts)	±(%rdg. + volts)		±(%rdg. + volts)	±(%rdg. + volts)
±10.000 V	400 μV	0.1% + 6 mV	0.07% + 4 mV	10 μV	0.1% + 1 mV	0.06% + 540 μV

VOLTAGE OUTPUT SETTling TIME: <300μs to 0.1% typical, resistive load after command is processed³.

VOLTAGE OUTPUT SLEW RATE: <0.01V/μs typical², resistive load after command is processed.

VOLTAGE NOISE: 10μV rms, 0.1Hz to 10Hz typical².

CURRENT LIMIT: 10mA^{3,8}.

MAXIMUM CAPACITIVE LOAD: 20nF on 10μA and 500μA range, 35nF on 10mA range.

MISCELLANEOUS

AUTOMATIC OFFSET COMPENSATION: The user can command the 451x-QIVC to disconnect itself from the device under test and measure and store any offsets in the source and measure circuitry so that future measurements are appropriately compensated.

VOLTAGE SOURCE CURRENT MEASUREMENT

Range	MEASUREMENT ACCURACY (1 Year) (23°C ±5°C)	MEASUREMENT ACCURACY (24 Hour) ¹ (23°C ±1°C)	DEFAULT MEASUREMENT RESOLUTION
	±(%rdg. + current)	±(%rdg. + current)	
±10.000 μA	0.1% + 15 nA	0.063% + 12 nA	0.1 nA
±500 μA	0.1% + 70 nA	0.063% + 55 nA	10 nA
±10.0000 mA	0.1% + 1.4 μA	0.063% + 1.1 μA	100 nA

VOLTAGE BURDEN: <14mV³.

1.888.KEITHLEY (U.S. only)

www.keithley.com



4500-MTS

Multi-Channel I-V Test System

Series 451x-QIVC Specifications (continued)

OUTPUT ISOLATION

This information is when the output state is set to OPEN (Hi-Impedance).

TYPICAL ISOLATION LEAKAGE CURRENT: 30nA.

MAXIMUM ISOLATION VOLTAGE: 40V DC.

MAXIMUM ISOLATION RELAY SETTling TIME: 10ms.

GENERAL SPECIFICATIONS

DIGITAL INTERFACE:

Safety Interlock:

- Customer provided closed contact on a per-channel basis, to enable output.
- On a channel group basis, opening of customer provided contacts disconnects the sources from loads on the Voltage Source and Current Source. 5-volt level, 500Ω input impedance.

Supplies: +5V (fused ½ amp) and Ground.

OVERRRANGE: 105% of Range (Source Functions), 110% of Measure (Measure Functions).

COMMON MODE VOLTAGE: ±20V DC maximum.

WARM-UP TIME: 1 hour.

OVER-TEMPERATURE: Two on-board over-temperature detectors.

ENVIRONMENT: Accuracy specifications are multiplied by one of the following factors, depending upon the ambient temperature and humidity.

TEMPERATURE	% RELATIVE HUMIDITY	
	5-60	60-70
10° - <18°C	×3	×3
18° - 28°C	×1	×3
>28° - 40°C	×3	×5

WEIGHT (approx.): 0.9kg (2 lbs.).

NOTES:

- The 24 hour specification applies only for the 24 hour period immediately following an Auto-Offset, and ±1°C of the temperature at which the Auto-Offset was performed, and within 1 year of calibration.
- 95% CI based on measured data on 20 sample units.
- As guaranteed by design.
- Includes cable inductance.
- For example, the total uncertainty of a current sourcing 1A on the 1A range into a perfect short of 0V would be:

$$(0.08\% \times 1A) + (250\mu A) + (144\mu A) \times (|0V/6V| - |1A/1A|)$$

$$= (80\mu A) + (250\mu A) + (144\mu A)$$

$$= 474\mu A$$
 The generic equation of the third error term is:

$$\text{Amps} \times \left(\left| \frac{V_{out}}{V_{FS}} \right| - \left| \frac{I_{out}}{I_{FS}} \right| \right)$$
- Includes 2 meter accessory cable while excluding IR drop in DUT leads.
- Slew rates apply for resistive loads: Rload <200Ω for 30mA range, Rload <60Ω for 100mA range, and Rload <12Ω for 500mA range.
- Hardware limited.

Model 4500-MTS Chassis Specifications

DESCRIPTION

The Model 4500-MTS is a fully integrated, instrument grade industrial computer with the following features:

- Total of 10 PCI slots, with 9 PCI instrument slots available to user. One ISA instrument slot. One PICMG CPU slot.
- Trigger bus for cross-card measurement synchronization. Dedicated connector on each instrument slot.
- High power, low noise instrument grade power supply. Dedicated connector on each instrument slot.
- Embedded PC with Windows operating system.
- SVGA interface for driving an external monitor.
- 10/100 Base-T LAN interface.
- USB interface.
- RS-232 interface.
- Printer interface.
- Hard disk drive.
- CD-RW disk drive with software.
- Floppy disk drive.
- Steel chassis with enhanced cooling, painted cover, and plastic front bezel.
- Optional integrated Flat Panel Display.
- Full size keyboard with integrated pointing device.

ACCESSORIES

The following Keithley products are currently validated for use with the 4500-MTS:

- KPCI-PIO32IOA and KPCI-PDIS08A (16I/16O and 8I/8O Isolated Digital I/O)
- KPCI-3130 and KPCI-3132 (8 and 2 channel Analog Output)
- KPCI-3110 (1.25MHz Multifunction AIO PCI Card)
- KPCI-3116 (250kHz Low Gain AIO PCI Card)
- KPCI-3108 and KPCI-3107 (100kHz Multifunction AIO (3108) AI (3107))
- DAS-1801HC (333kHz AIO ISA Card)
- PIO-32 (32-Channel Isolated Digital I/O ISA Card)
- KPCI-488.2 GPBI PCI Card

Other Keithley PCI and ISA cards could be used with the Model 4500-MTS, but compatibility has not been verified at the time of this printing.

SYSTEM BACKPLANE

PCI SLOTS: Ten total. Nine slots are available for PCI instrumentation. One slot reserved.

COMPLIANCE: PCI 2.1-2.3 (determined by embedded PC).

ISA SLOTS: One 16-bit slot.

COMPLIANCE: PICMG 2.0.

PCI/ISA SLOTS: One.

COMPLIANCE: PICMG 2.0.

SIDEBAND/TRIGGER BUS

Reserved for use by 451X instrument cards.

SYSTEM POWER SUPPLIES

The 4500-MTS mainframe utilizes two power supplies. The ATX power supply provides power to the computer components (e.g., embedded PC, disk drives, etc.) and PCI bus. The Instrument power supply provides 48V power to the 451X instrument card output stages.

ATX POWER SUPPLY: 70 watts max.

Output Voltage (Max. Current): +3.3V (14A), +5V (20A), -5V (0.3A), +12V (6A), -12V (0.8A).

INSTRUMENT POWER SUPPLY: +48V (16A max).

EMBEDDED PC

PROCESSOR: Intel Pentium 4, 2GHz.

CHIPSET: Intel 845.

MEMORY: Up to 2GB, 200/266MHz DDR SDRAM on two 184-pin DIMM sockets.

VIDEO: ATI Mobility M6 graphics controller, 16Mbytes 200MHz DDR SDRAM display cache. Flat panel LVDS support and simultaneous SVGA support.

LAN: 10/100 Base-T. RJ-45 connector on option card retaining bracket.

USB: One port on option card retaining bracket (Type 2).

SERIAL: One port, 9 pin, COM1.

PARALLEL: One port, 25 pin.

IDE: Two EIDE ports with ULTRA DMA 33/66/100 support.

FLOPPY: One port.

KEYBOARD/MOUSE: One 9-pin DIN connector on option card retaining bracket. Y-cable provided.

DISK DRIVES

HARD DRIVE: Interface: EIDE; capacity 40GB.

FLOPPY DISK: Size: 3.5"; capacity 1.44MB.

CD-RW: Interface: ATAPI, EIDE.

CHASSIS

MATERIAL: Stainless steel inner chassis and rear panel. Painted steel cover.

FAN: High reliability cooling fan.

GENERAL SPECIFICATIONS

POWER SUPPLY:

Power Per Slot Max.: 96W for 48V; 8.75W for ATX.

Mains: Pushbutton ON/OFF switch/fuse/power module combo.

TEMPERATURE:

Operating: 0° to +40°C (with no accessory cards).

Storage: -15° to 60°C.

HUMIDITY:

Operating: 5% to 70% RH, non-condensing.

ALTITUDE:

Maximum 2000m above sea level. For internal use only.

POWER REQUIREMENTS:

100-240VAC, 50/60Hz.

INPUT POWER RATING:

1kVA.

WARM UP TIME:

One hour.

REGULATORY COMPLIANCE:

Safety: Conforms to European Union Directive 73/23/EEC, EN61010-1, CAT I.

EMC: Conforms to European Union Directive 89/336/EEC, EN61326-1.

Vibration: MIL-PRF-28800F Class 3, Random.

DIMENSIONS:

22.3cm high × 43.6cm wide × 56.5cm deep (8.75 in. × 17.2 in. × 22.25 in.).

WEIGHT (approx.):

26.3kg (58 lbs.) for base system (excluding multi-channel cards, cables, keyboard, etc.).

1.888.KEITHLEY (U.S. only)

www.keithley.com

KEITHLEY